



TÜVRheinland®

DIN CERTCO

Precisely Right.



Certification Scheme

Wood Briquettes

according to

DIN EN ISO 17225-3

(Edition: May 2023)

Foreword

DIN CERTCO was founded in 1972 by DIN Deutsches Institut für Normung e. V., is now part of the TÜV Rheinland Group and is the certification body for issuing DIN marks and other certification marks for products, persons, services as well as companies based on DIN standards and similar specifications. Due to its independence, neutrality, competence and many years of experience, DIN CERTCO enjoys a high reputation both at home and abroad.

In order to prove the functionality of the system and our competence as a certification body, we have been accredited, certified or recognised by independent domestic and foreign bodies in both the voluntary and legally regulated areas. [Our accreditations.](#)

This certification scheme defines the requirements for wood briquettes according to the standard DIN EN ISO 17225-3. The revision of this certification scheme comes in conjunction of update of the ISO Standard in 2021. Wood briquettes receive the quality mark “DINplus” on meeting the requirements listed under section 3 according to the procedure described in this certification scheme.

This certification scheme is in addition to the General Terms and Conditions of DIN CERTCO the basis for suppliers of wood briquettes to mark their products with the quality mark “DINplus” into law. In this way they document that their products fulfil all the requirements of the DIN EN ISO 17225-3 and beyond that.

The quality mark “DINplus” creates the confidence that an independent, neutral and competent certification body has carefully examined and assessed the product quality on the basis of the test criteria defined by the standards and the certification scheme. The market surveillance by third-party monitoring also ensures that the product quality is maintained even during ongoing production. In this way, the customer receives an added value, which he can take into consideration in deciding on his purchase behavior.

All certificate holders can be viewed on the daily updated database on the homepage of DIN CERTCO <www.dincertco.de>

Start of validity

This certification scheme is valid from 2023-05

Revision

Changes done in the Certification Scheme Wood Briquettes (2020-03) in accordance with DIN EN ISO 17225-3 are as follows:

- Definition of raw materials
- Definition of shape of wood briquettes according to new ISO standard
- Editorial changes

Previous editions

Certification Scheme “Wood briquettes” (2020-03)
 Certification Scheme “Wood briquettes” (2018-01)
 Certification Scheme “Wood briquettes” (2015-06)
 Certification Scheme “Wood briquettes” (2011-09)
 Certification Scheme “Untreated wood briquettes” (1997-04)

CONTENTS

1	Scope	5
----------	--------------------	----------

2	Test and certification specifications	5
3	Product requirements	5
3.1	Raw material	5
3.1.1	Contamination, foreign substances.....	5
3.2	Shapes of wood briquettes	6
3.3	Specification of wood briquettes	7
3.4	Marking	7
4	Testing	8
4.1	General Information	8
4.2	Types of test	8
4.2.1	Initial test	8
4.2.2	Surveillance test	8
4.2.3	Supplementary test.....	8
4.2.4	Special test.....	9
4.3	Sampling as a part of the surveillance test	9
4.4	Test procedure	9
4.4.1	Moisture content	9
4.4.2	Ash content	9
4.4.3	Particle density	9
4.4.4	Calorific value.....	9
4.4.5	Mechanical durability of wood briquettes (abrasion)	10
4.4.6	Nitrogen content	10
4.4.7	Sulphur and chlorine content	10
4.4.8	Foreign substances	10
4.5	Test report.....	10
5	Certification	10
5.1	Application for certification	10
5.2	Definition of types and sub-types	11
5.3	Conformity assessment.....	11
5.4	Certificate and the right to use the mark.....	11
5.4.1	Additional production facility	12
5.4.2	Sublicenses	12
5.5	Publications.....	12
5.6	Validity of certificate	12
5.7	Renewal of certificate	12
5.8	Expiry of certificate	12
5.9	Alterations/Amendments	13
5.9.1	Alterations/Amendments to the product	13
5.9.2	Amendment of the test basis	13
5.10	Defects in the product	13
6	Self-monitoring by the certificate holder	14
6.1	Production-accompanying quality assurance	14

6.2	Quality Management System	15
7	External monitoring by DIN CERTCO	15
7.1	General information.....	15
7.2	Monitoring in the market.....	15

1 Scope

This certification scheme is applicable to wood briquettes property class A1 of the standard DIN EN ISO 17225-3 with regard to the additional testing of the mechanical strength of wood briquettes in accordance with DIN EN ISO 17831-2 and contains in conjunction with the documents mentioned below all the requirements for awarding of the Quality Mark “DINplus”.

This certification scheme specifies the requirements for the product itself and on its testing, monitoring and certification as well.

2 Test and certification specifications

The basis for the testing and certification are the following documents listed below in their respective valid version. For dated references, only the edition cited applies. For undated references, the latest edition of the referenced document (including any amendments) applies.

DIN EN ISO 17225-3	Solid biofuels – Fuel specifications and classes – Part 3: Graded wood briquettes
DIN EN 15234-3	Solid biofuels – Fuel quality assurance. – Part 3: Wood briquettes for non-industrial use
DIN EN ISO 17831-2	Solid biofuels – Determination of mechanical durability of pellets and briquettes – Part 2: Briquettes

- This Certification Scheme
- The General Terms and Conditions of DIN CERTCO
- The respective schedule of fees of DIN CERTCO

3 Product requirements

3.1 Raw material

Wood briquettes may be produced from natural wood and chemically untreated wood residues or bark in natural state or also including additives. Permitted are the following timber classes according to DIN EN 17225-1:2021, Table 1 for the property class A1:

- forest, plantation and other virgin wood
- chemically untreated wood residues

The producer of wood briquettes must keep a record of the origin of wood being used for the production of briquettes including a list of the suppliers approved by him.

3.1.1 Contamination, foreign substances

Negligible levels of glue, grease and other timber production additives used in sawmills during production of timber and timber product from virgin wood are acceptable if all chemical parameters of the briquettes are clearly within the limits and concentrations are too small to be concerned with.

3.2 Shapes of wood briquettes

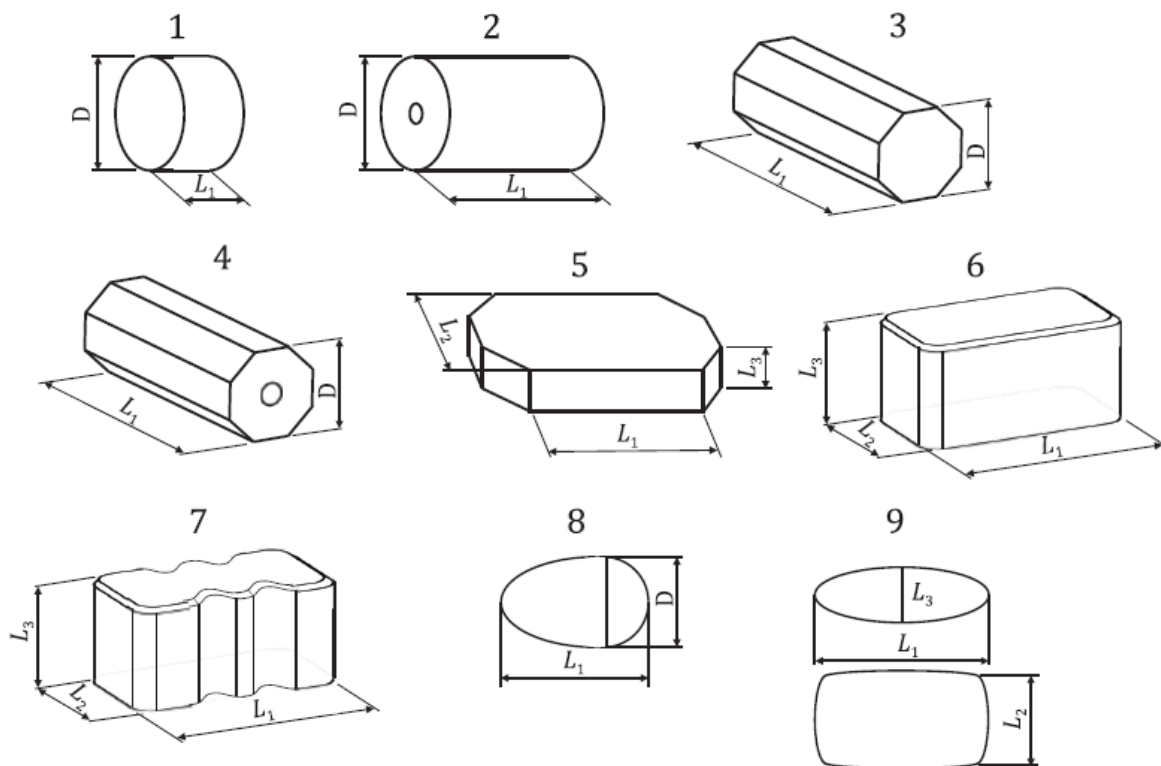

Figure 1 – Dimension of briquettes according to DIN EN ISO 17225-3

Key

- D diameter
- L₁ length
- L₂ width
- L₃ height or diameter for cylinder briquettes

3.3 Specification of wood briquettes

Table 1

Property class	Units	Requirements
Dimension	mm	Diameter, width and length to be specified
	shape	Specify shape according to section 3.2 e.g. 1 or 2, etc.
Surface area of briquettes, including the hole surface, if any	cm ² / kg	can be specified
Moisture	w-%	≤ 12
Ash content	w-%, dry	≤ 1.0
Particle density ¹⁾	g/cm ³	≥ 1.0
Additives ²⁾	w-% dry	≤ 2 Type and amount to be stated
Net calorific value	MJ/kg	≥ 15,5
	kWh/kg	≥ 4,3
Mechanical durability	w-%	≥ 95
Nitrogen, N	w-% dry	≤ 0,3
Sulphur, S	w-% dry	≤ 0,04
Chlorine, Cl	w-% dry	≤ 0,02
Arsenic, As	mg/kg dry	≤ 1
Cadmium, Cd	mg/kg dry	≤ 0,5
Chromium, Cr	mg/kg dry	≤ 10
Copper, Cu	mg/kg dry	≤ 10
Lead, Pb	mg/kg dry	≤ 10
Mercury, Hg	mg/kg dry	≤ 0,1
Nickel, Ni	mg/kg dry	≤ 10
Zinc, Zn	mg/kg dry	≤ 100
¹⁾ Particle density ≥ g/cm ³ is accepted for class A1 for hydraulically compressed briquettes ²⁾ Type of additives to aid production, delivery or combustion (e.g. pressing aids, slagging inhibitors or any other additives like starch, corn flour, vegetable oil, lignin). Type and amount of additive(s) shall be stated.		

3.4 Marking

The packaging or accompanying documents (in the case of unpackaged delivery) must be permanently legible and marked in German and / or in the national language of the sales market with the following information:

- Name or registered trademark of the manufacturer or the supplier/distributor
- Designation of product with inscription of the diameter, width and length (in mm) and shape, e. g. wood briquettes – diameter 80 mm, length 300 mm, shape 2
- Nominal weight
- The combustion may be carried out in approved and licensed fireplaces only (see operating instructions of the fireplace). Please, pay attention that this notice must be written literally.
- Advice for the proper storage and combustion of wood briquettes. You could write e.g.: store the wood briquettes dry and airy please. Fill your stove according to its construction only. The compacted swarf expands when heating. We recommend splitting of the wood briquettes 2 until 3 times. You should never overfeed the furnace. Please fill the

combustion chamber of the furnace not more than half. Do not lock the furnace before the complete burning good is died down. Provide out-reaching change of air. Not ignite the fire with highly flammable liquids such as alcohol, spirit or petrol.

- The reference in terms of the environment protection: “The packing may not be burned with.”
- Production year (it has always to be updated)
- The quality mark “DINplus” with the corresponding registration number.
- If more than one production plant a clear differentiator must be created, e.g. number, letter or any else can be selected. (The marking has to be announced to DIN CERTCO in written form.)
- Inscription of the standard: DIN EN ISO 17225-3 (optional)

4 Testing

4.1 General Information

DIN CERTCO is working with qualified test laboratories to carry out the necessary tests as the basis for the evaluation and certification of the products.

4.2 Types of test

4.2.1 Initial test

The initial test is a type test (design test, type test), which serves to determine whether the product meets the requirements laid down in section 3 of this certification scheme and whether the requirements for the product are met. The initial test consists of a laboratory test of the samples, which are taken from all production facilities and submitted for testing to a laboratory and documented in the test report.

The test is carried out in accordance with section 4.4 of this certification scheme.

The test must be proven in time by a positive test report.

4.2.2 Surveillance test

The verification test is carried out at recurring, defined intervals (see section 7 of the certification scheme) and serves to determine whether the certified product corresponds to the type-tested product in the production phase.

This test is carried out in accordance with section 4.4 of this certification scheme.

The testing of the samples taken on the market is ordered by DIN CERTCO and must be proven in time by a positive test report.

As part of the factory production control by the certificate holder according to section 6 of the certification scheme, the conformity of the manufactured products with the specified requirements should be ensured. This must be proven in time by a positive test report.

4.2.3 Supplementary test

A supplementary test takes place if additions, extensions or changes (see section 5.9 of the certification scheme) have been made to the already certified product that have an impact on the conformity with the underlying requirements.

The type and scope of the supplementary test are determined in individual cases by DIN CERTCO in consultation with the testing laboratory.

4.2.4 Special test

A special test is conducted when:

- defects are detected
- the production has been suspended for a period of more than 6 months
- required by DIN CERTCO - reasons to be specified
- requested in writing by a third party if a particular interest in the maintenance of proper conduct of market procedures in relation to competition or quality is involved.

The type and scope of a special test are determined in accordance with the purpose in each individual case by DIN CERTCO in coordination with the test laboratory.

If defects are found during a special test, or if it is a special test due to production being suspended, the certificate holder must bear the costs of the special test procedure.

If no defects are found in the case of special tests at the request of third parties, the costs will be borne by the applicant third party.

4.3 Sampling as a part of the surveillance test

Sampling takes place in the course of monitoring in the market (see section 7.2 of the certification program) and it is usually carried out by the inspector ordered by DIN CERTCO. The test samples are taken from the trade and sent to the test laboratory ordered by DIN CERTCO. The applicant bears the costs for this

The samples (at least 10 kg wood briquettes) for the initial test and laboratory test upon renewal of certificate are usually delivered by the manufacturer to the testing laboratory being ordered with the test by DIN CERTCO. The applicant bears the costs for this.

To test of the mechanical strength, the sample consists of 15 non-destroyed wood briquettes. For wood briquettes of type A according to DIN EN ISO 17831-2 (briquettes with a mass < 0.5 kg in the delivery state), the sample must be at least 10 kg. This test is automatically ordered with the application for certification.

4.4 Test procedure

4.4.1 Moisture content

The moisture content is determined according to ISO 18134-1, ISO 18134-2.

4.4.2 Ash content

The ash content is determined according to ISO 18122.

4.4.3 Particle density

The particle density is determined according to ISO 18847.

4.4.4 Calorific value

The calorific value is determined according to ISO 18125.

4.4.5 Mechanical durability of wood briquettes (abrasion)

The mechanical durability is determined according to DIN EN ISO 17831-2.

4.4.6 Nitrogen content

This is determined according to ISO 16948.

4.4.7 Sulphur and chlorine content

This is determined according to ISO 16994.

4.4.8 Foreign substances

These are determined according to ISO 16968.

The requirements are considered to be met even if the test laboratory determines results of small finding quantities of the analytical method and the limit of finding of the analytical method is equal to the limit value.

4.5 Test report

The test laboratory shall notify the client of the results of the tests in a test report. This must be submitted to DIN CERTCO in the original. The test report may not be older than 6 months at the time of application. In individual cases, older test reports may also be recognized if the test laboratory confirms in writing the validity of the information given in the test report.

The test report shall comply with DIN EN ISO/IEC17025 and shall include at least the following information:

- Name and address of the manufacturer
- Name and address of the applicant (if different from manufacturer)
- Test principles (standards and certification scheme) incl. date of issue
- Type of test (e.g. type test, supplementary test, etc.)
- Date of the test
- Results and assessment of the test
- Name and signature of the person responsible for the test

5 Certification

5.1 Application for certification

Applicants may be producers or distributors who, in written agreement with the certificate holder, place the products on the market under their own responsibility as defined by the Product Safety Act (in German: Produktsicherheitsgesetz).

The applicant must submit the following documents to DIN CERTCO:

- Application for certification in the original and with a legally binding signature
- Current test report according to Section 4.5 on an initial test (see Section 4.2.1), unless the test was commissioned by DIN CERTCO
- Proof of current certification according to DIN EN ISO 9001 (appropriate)
- If applicable, documents in accordance with European legislation on hazard and safety information

Certification within the meaning of this certification scheme is the conformity assessment of a product by DIN CERTCO based on test reports from a qualified testing laboratories. The products to be certified are checked for conformity (accordance) with the requirements listed in section 3.

A test shall be carried out for each manufacturing facility, which shall contain a clear and detailed reference to the products subject to surveillance.

The right of use for the quality mark "DINplus" is granted by issuing a corresponding certificate.

5.2 Definition of types and sub-types

Wood briquettes that differ from each other in essential certification-relevant features are defined as a type. Features relevant to certification are e.g. B. Properties that significantly affect security, function or handling and are therefore sold under its own trade name. A separate certificate is issued for each type.

Types of wood briquettes differ in their origin from the raw material, their shape and their size. If there are deviations in the dimensions of wooden briquettes of more than 10%, an independent certificate will be issued.

As a rule, sub-types are those products of a type/model that only differ from one another in formal or non-certification-relevant features. They can be summarized on a certificate, e.g. packaging sizes.

5.3 Conformity assessment

Based on the submitted application documents DIN CERTCO carries out the conformity assessment. In particular, the test report assesses whether the product meets the requirements of the certification scheme and the standard.

DIN CERTCO informs the applicant in writing about deviations.

5.4 Certificate and the right to use the mark

After successful testing and conformity assessment of the submitted documents, DIN CERTCO issues a certificate to the applicant and awards the right to use the quality mark "DINplus" in conjunction with a corresponding registration number.



Structure of the registration number: **9H000**

Wood briquettes, for which the right to use the quality mark “DINplus” has been awarded, must be marked with the respective quality mark “DINplus” and the respective registration number.

The mark and the registration number may only be used for the type for which the certificate has been issued and which corresponds to the type-tested product.

For each respective type, a registration number shall be issued. For design types (sub-types) of a type, the same registration number shall be issued (see section 5.2).

In addition, the General Terms and Conditions of DIN CERTCO apply.

5.4.1 Additional production facility

DIN CERTCO must be notified of each additional production facility. If a corresponding test report is available and the product meets the requirements of the standard, the product can also be produced in the other manufacturing facility with the quality mark “DINplus” and with the existing register number.

5.4.2 Sublicenses

It is necessary to issue a sub-certificate, when a certified type/model of type of wood briquettes is marketed by another company as a (main) certificate holder or under a trade mark other than the (main) certificate.

5.5 Publications

All certificate holders can be viewed on the daily updated homepage of DIN CERTCO www.dincertco.tuv.com. Producers, users and consumers use this research possibility for obtaining information about the certified products.

Besides the contact data of the certificate holders (telephone, telefax, e-mail, homepage), it is also possible to view the technical data of the certified products.

5.6 Validity of certificate

The certificate has a validity of 2 years. The validity period is indicated in the certificate. If the certificate is extinguished, the right to use the right to sign expires.

5.7 Renewal of certificate

If the certification is to be maintained beyond the validity period specified in the certificate, DIN CERTCO must have a current positive test report in good time before the validity expires.

Evidence of compliance with the requirements of the test and certification basis in accordance with Section 2 is provided in the scope of a surveillance test in accordance with Section 4.2.2.

5.8 Expiry of certificate

Insofar as the re-testing for standard conformity according to section 4 has not taken place in due time before the end of the period of validity, the right of use for the quality mark

"DINplus" and the registration number expires without DIN CERTCO's direct notification being required.

In addition, the certificate may expire if:

- the surveillance measures referred to in section 7 are not carried out on time or incompletely
- the quality mark "DINplus" is abused by the certificate holder
- the requirements resulting from this certification scheme or its accompanying documents are not fulfilled
- the applicable certification fees are not paid in due time
- the conditions for issuing the certificate are no longer fulfilled

5.9 Alterations/Amendments

5.9.1 Alterations/Amendments to the product

The certificate holder is obligated to inform DIN CERTCO immediately of any changes to the product. DIN CERTCO decides, in consultation with the testing laboratory, to what extent an inspection according to section 4.2.3 is to be carried out and whether this is a significant change. The test report is forwarded by the test laboratory to DIN CERTCO.

If DIN CERTCO establishes a major change, the certificate expires with the associated registration number. For the amended product, an application for initial certification and the right of use for the certification mark "DINplus" can be submitted again.

The certificate holder is also obliged to notify all changes to formal data of DIN CERTCO (e.g. certificate holder or its address).

Every new production facility is to be known to DIN CERTCO. If a corresponding test report is available and the product fulfills the requirements of the standard, after agreement of DIN CERTCO in writing may also be marked with the mark "DINplus" and the already existing registration number.

5.9.2 Amendment of the test basis

If the basic test specifications for the certification are modified, an application for the alteration of the certification shall be submitted within 6 months after receiving of notification from DIN CERTCO and, as a rule, after 12 months, proof of conformity with the modified test specifications shall be submitted in the form of a positive test report (see section 4.2.3).

5.10 Defects in the product

If deficiencies in a certified product being in the market are detected, DIN CERTCO requests the certificate holder in writing to eliminate the defects.

DIN CERTCO, in consultation with the testing laboratory, decides whether it is a serious or minor defect.

In the case of defects that directly or indirectly have an influence on safety or functional performance (serious defects), the certificate holder has to ensure that the products are no longer marked with the certification mark until the defects are eliminated.

The deficiencies must also be eliminated immediately on installed or in stock products. Within 3 months, the certificate holder must prove to DIN CERTCO by submitting a test

report on a special test according to section 4.2.4 that the deficiencies have been removed and that the complained product meets the specified requirements again.

In the case of defects, which do not have any influence on the safety or functional performance (minor defects), the certificate holder has to document to DIN CERTCO within 3 months and in a suitable way that the defects of the complained product have been removed.

If the certificate holder fails to meet these deadlines, the certificate and therefore the right of use for the certification mark "DINplus" will be withdrawn.

If there is still reason for the complaint, DIN CERTCO initially suspends the certificate and at the same time, a final deadline for the elimination of defects is given. If the certificate holder fails to comply with the request or fails to comply with the deadline, or the removal of defect cannot be proved again, the certificate will be expired.

6 Self-monitoring by the certificate holder

The certificate holder must ensure that the product properties confirmed during the certification are maintained by means of appropriate quality assurance measures. This can be ensured by means of a factory-specific production control, which is directly aligned with the product or the production and through measures within the framework of a quality management system (QM system) in accordance with the series of standards DIN EN ISO 9000 ff. If there is the QM system certified according to DIN EN ISO 9001 available, the production control must be carried out based on a statistical check according to the international standard DIN ISO 2859-1.

6.1 Production-accompanying quality assurance

The factory production control is the continuous monitoring of the production process by the certificate holder, which ensures the conformity of the manufactured products with the stipulated requirements.

Corresponding test report is to be submitted to DIN CERTCO as a rule after 12 months from the issue date of the certificate.

The test report shall comply with DIN EN ISO/IEC17025 and shall include at least the following information:

- Name and address of the manufacturer
- Name and address of the applicant (if different from manufacturer)
- Test principles (standards and certification scheme) incl. date of issue
- Type of test (e.g. type test, supplementary test, etc.)
- Date of the test
- Results and assessment of the test
- Name and signature of the person responsible for the test

In case of a negative result of testing, the certificate holder must immediately take all measures for the removal of the defect. Defective products shall be marked and discarded. The test shall be repeated on a regular basis to determine whether the defect has been removed.

6.2 Quality Management System

DIN CERTCO recommends the establishment and certification of a quality management system according to the international standard DIN EN ISO 9001.

7 External monitoring by DIN CERTCO

7.1 General information

An essential part of the certification is the continuous monitoring of the certified product during the entire duration of the certificate. The monitoring by DIN CERTCO during the duration of the certificate takes place twice.

DIN CERTCO verifies and evaluates the conformity of the product with the requirements laid down in the certification scheme as well as the effectiveness of the quality assurance as per section 6.1.

7.2 Monitoring in the market

Monitoring in the market by DIN CERTCO is used to determine whether the manufacturing conditions for continuous conformity of the products with the requirements of section 3 are met. In the course of the monitoring, representative samples are taken from the trade. The sample quantity is determined in accordance with the provisions of section 4.3 of the certification scheme. The test scope is defined in section 4.4.

If possible, monitoring in the market is unannounced and must be carried out at least once a year for each certified product. The samples taken are tested by a qualified test laboratory. They should correspond to the average of production. Sampling is carried out on the entire sales article of the certificate holder in the market.

In order to be able to identify the samples of certified product in the market, DIN CERTCO must have an information on whether the samples remain in the retail trade so that samples of the certified product that are on the market can be taken. This information can be available to DIN CERTCO as a list or on request.

If the results of the test are not sufficient, the certificate holder must be notified without delay. The scope of additional measures to meet all requirements must then be defined between the certification body and the certificate holder. If the holder of the certificate is unable to implement the required measures, the procedure is interrupted and the certificate suspended. If the certificate holder fails to comply with the request or fails to comply with the deadline, or the removal of defect cannot be proved again, the certificate will be expired.